



2018+ JEEP JL SEQUENTIAL 7" X 8" 30W LED TAILLIGHTS

QTE1026



VER: 20-2

INTRODUCTION:

Thank you for purchasing our Plug-in-Play Jeep JL LED Tail Lights. Carefully remove all the components and examine for any missing parts or visible damage caused by shipping and report any damage to the carrier and keep the shipping package. Take a good look at all the components so you are familiar with them before digging into this.

PARTS LIST:

1. DRIVERS SIDE TAIL LIGHT
2. PASSENGER SIDE TAIL LIGHT
3. TURN SIGNAL AdapterS (x2)
4. BRAKE SIGNAL Adapter
5. LIGHTHACKER MODULE (x2)
6. QUICK CRIMP (x2)
7. SPLITTER MODULE (x2)

REQUIRED TOOLS :

- T40 Torx or 10mm Socket
- Socket Wrench
- Screwdriver or Nylon Panel Removal Tool

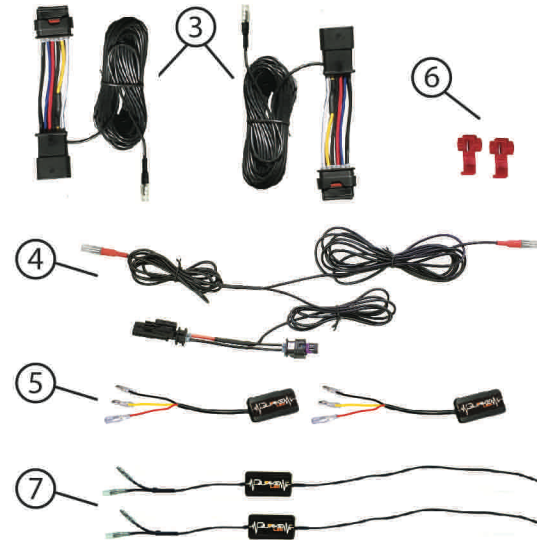
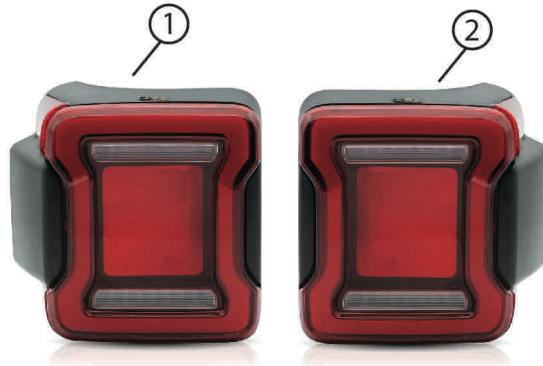

Record any serial no. here _____

WARNING:

Read all instructions and warnings before installing and using.

INSTALLER: This manual must be delivered to the end user of this equipment.

INSTALLATION

Step 1. Open the swinggate. (Photo 1)

Step 2. On the back wheel well, you will see small 2"x2" plastic access covers.

Step 3. Starting on the drivers side. Use a Nylon Panel Remover or flathead screwdriver to remove this plastic cover. (Photo 2)

Step 4. Use a 10 mm socket to loosen and remove white plastic retaining bolt. This is the only thing holding the tail light to the vehicle, so you may want to keep a hand on the tail light while removing. Use caution with the long plastic MOPAR retaining screwhead. (Photo 3 & 4)

Step 5. Now you can remove the stock taillight. Unplug the factory taillight connector by depressing the release tab and pulling the two connectors apart.

Step 6. If you have the Blind Spot Monitoring system (B.S.M.). Otherwise you can skip to Step 10. You will want to remove and install the stock radar unit into your new tail lights. Lay the tail lights face down on a cloth as not to scratch the lenses.

Step 7. Remove the 3 self-tapping screws that are holding the tail pointy tail light mounting bracket to the new tail light. Remove the mounting bracket. (Photo 6)

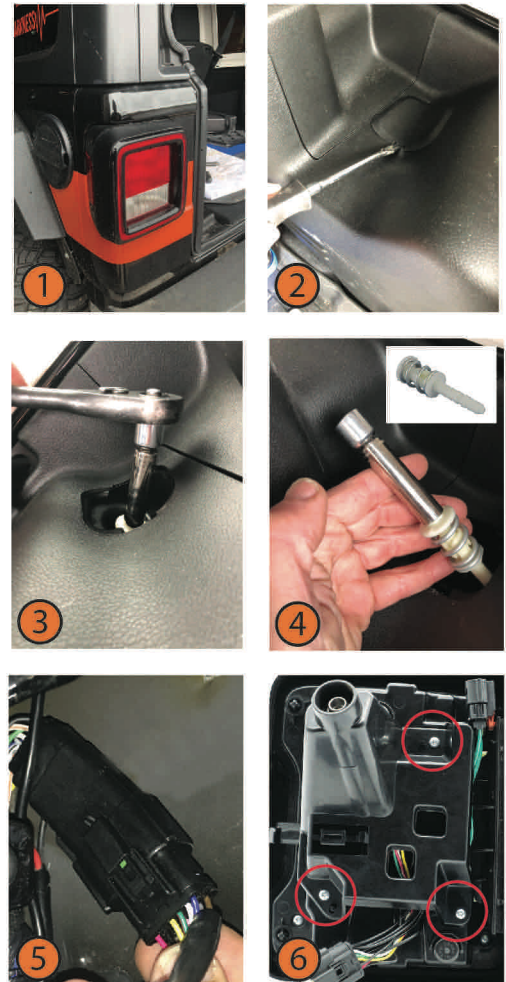

LIGHT UP THE DARKNESS



2018+ JEEP JL SEQUENTIAL 7" X 8" 30W LED TAILLIGHTS

QTE1026



VER: 20-2

Step 8. After removing the mounting bracket. You can now see the 2 radar mounting screws. Remove these 2 screws and take off the cover hiding the radar. (Photo 7 & 8)

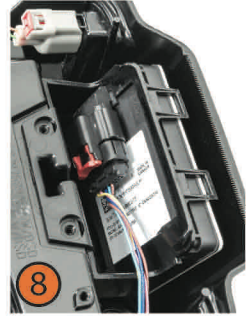

Step 9. Unlock and disconnect the radar connector from the stock tail light wire harness (Photo 9). You will now be able to remove the entire radar unit/mounting bracket (Photo 9) and install into the new tail light.



Step 10. If you plan to use Sequential Turn Signals via our LIGHT-HACKER. Proceed to Step 11. Otherwise now that you have the radar unit re-installed. Reverse steps 1 thru 9.

Enjoy your new high-quality Quake LED tail lights!

FUNCTION

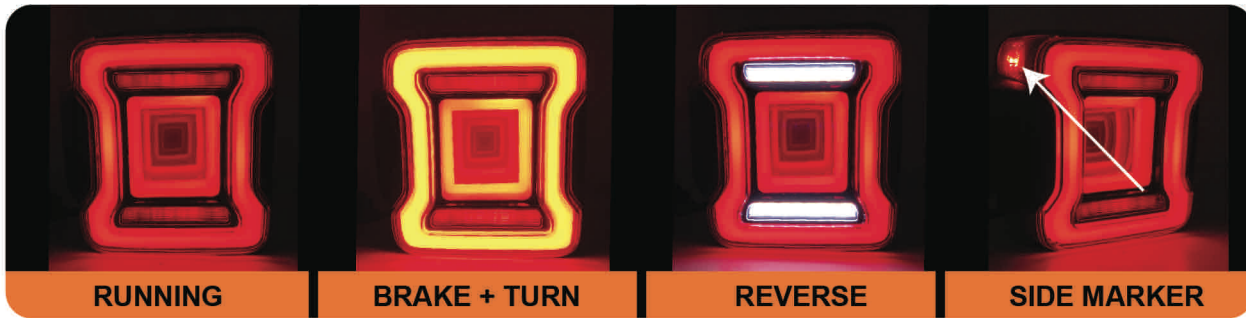

CONNECTOR

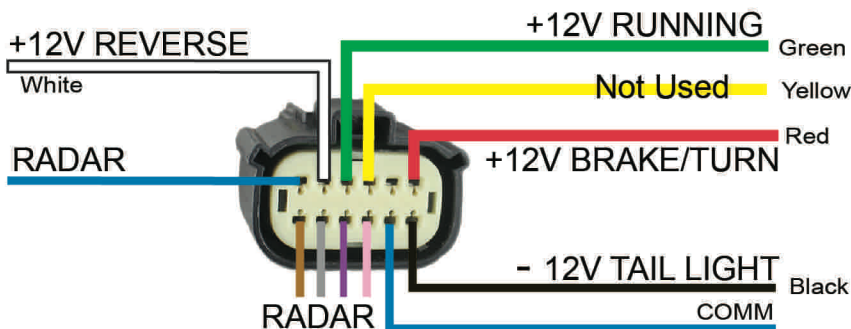

TAIL WIRING

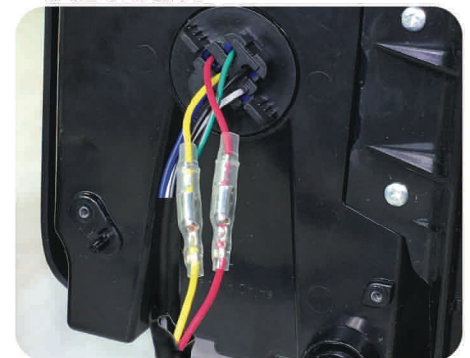

FAQ:

Q: How do get rid of moisture or condensation?

A: Remove all the ventilation breather covers on the back of the light while the tail light is on. The moisture will disappear within a short amount of time. Then reinstall the breather covers.



*-Wire Diagram is for Illustration Only.
-Actual wire harness lengths and wire gauge are not to scale.
-Actual wire harness components and lights are not to scale.*

LIGHT UP THE DARKNESS



LIGHTHACKER

Step 11. If you plan to use Sequential Turn Signals via LIGHTHACKER, keep reading and don't re-install the tail lights quite yet. You will still need to swap some tail light wire connections, flip a switch, install three wire Adapters, get into the tailgate panel and run the Adapter wires.

Step 12. Grab the tail lights. If you have not removed the cone shaped mounting bracket in Step 7. You must have this removed before proceeding forward. Unlock the central wire plug to get inside the tail light and flip a small rocker switch from O to I. This will activate the sequential turn signals.

Step 13. Next we need to find the drivers side fender DRL light wire harness/plug and connect the Inline Fender DRL Wire Adapters into that existing wire harness. You will access this harness/plug from inside the engine bay. Feel for the plug by standing on the drivers side and reaching into the engine bay where the fender liner meets the body. You will find this flat plug about 3/4 of the way up the engine bay/fender. This plug is secured to the body of the Jeep inside the engine bay near the rear of the plastic fender liner. Use a screw driver to remove the plug from the clip that holds it into the body. Once released you can pull the entire connector far enough into the engine bay to get at it to install the our inline wiring harness adapter.

Step 14. To undo the factory connectors, pull out the red tab outward at the end of the connector, then insert a small screwdriver into the connector latch at the end opposite the red tab. This should release the 2 halves of the connector.

Step 15. Plug our inline adapter into the 2 halves of the factory connector. Run the long black wire down and towards the driver side tail light following other wires along the chassis. Route wires so they are not touching any moving, sharp, hot parts. Run along areas with existing wires if possible. This bullet connector should end up at the drivers side tail light cavity where the tail light will mount.

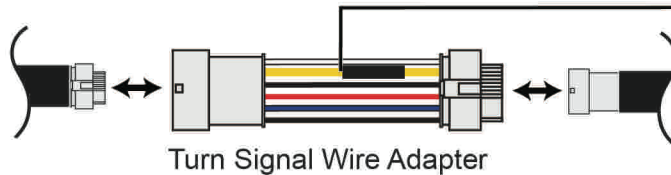
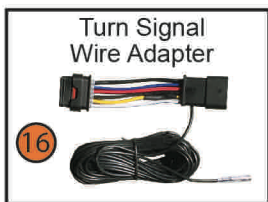
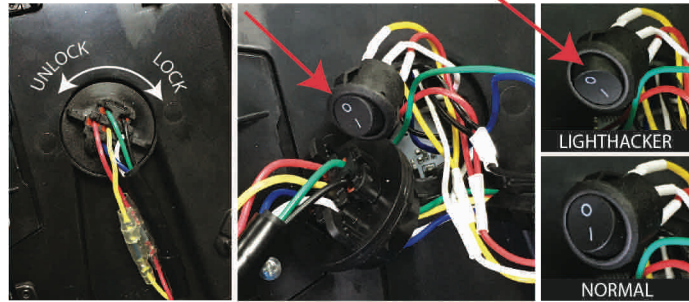
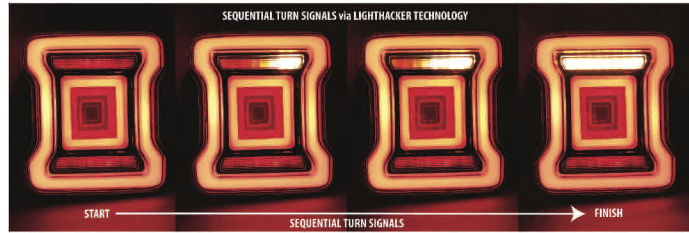

Step 16. The passenger side is a little bit more complicated because the factory DRL light wire harness/plug is hidden behind the three grounding wires and a plastic piece in the engine bay. Due to this, you will have to access the plug/harness by partially pulling back the passenger side inner fender liner. There are 2 plastic clips at the bottom of the fender liner and 4 more that run along the inside edge that you will have to remove.

-Wire Diagram is for Illustration Only.
-Actual wire harness lengths and wire gauge are not to scale.
-Actual wire harness components and lights are not to scale.





2018+ JEEP JL SEQUENTIAL 7" X 8" 30W LED TAILLIGHTS

QTE1026



VER: 20-2

Step 17. You will have to pop the fender liner over the plastic rivets in the fender but the holes are big enough that you do not need to drill out the rivets to do this. Just use a pry tool of some sort. There is one bolt that can be removed from the inner fender along with the clips to free up more space. Once the clips//bolt are removed the inner fender liner can be flexed back over the tire providing easy access to the plug. You could jack up the vehicle and remove the wheel to free up more space, but it is not necessary.

Step 18. While you have the fender liner peeled back you can unplug the factory fender light harness and push the ends of the plugs through the obvious gap into the engine bay. This will make accessing the plug in the future much easier because you will not have to peel back the fender liner again. You DO NOT need to remove the three grounding wires to relocate the plug.

Step 19. To undo the factory connectors, pull out the red tab outward at the end of the connector, then insert a small screwdriver into the connector latch at the end opposite the red tab. This should release the 2 halves of the connector.

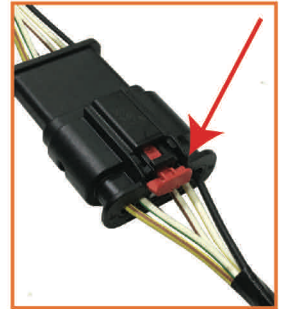

Step 20. Plug the Turn Signal Wire Adaptor into the 2 halves of the factory connector and test the fender lights. If your fender lights are still working correctly, run that long black turn signal wire towards the tail light cavity on it's respective side. Follow the chassis and route wires so they are not touching any moving, sharp, hot parts and next to existing wires if possible. Zip tie this adaptor to existing wires.

Step 21. Re-attach the fender liner using the bolt and the plastic plugs. Complete the installation by using cable ties to secure the wire running back to the tail lights



Brake Signal Wire Adapter

Step 22. Now we need to install the Brake Signal Wire Adapter that connects into the stock wire harness in the tail gate. Identify which tailgate panel you have because there are two versions that differ in the small upper panel embedded within the larger panel. Remove the Jeep logo tailgate panel that has the JEEP logo in the main panel use a nylon interior trim remover tool or nylon pry tool to pop the panel off. Next use the nylon interior trim remover tool to pry the entire rear panel off of the tailgate starting in the upper right corner.



Step 23. Next we need to find the Brake harness/plug inside the JL's tail gate and connect the Inline Brake Signal Wire Adapter into the existing Fender DRL wire harness. You can access this by carefully taking off tail gate plastic panel that will expose all the internal wiring. You will see 3 wire harness at the opening side and the wire harness we want is the middle one.

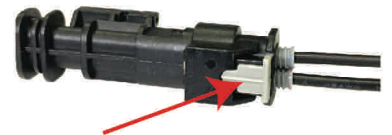

Step 24. To undo the factory connectors, pull out the gray tab outward at the end of the connector, then press onto that gray tab and the latch will release. Pull the two apart and plug our Brake Signal Wire Adapter into the 2 halves of the factory connector.

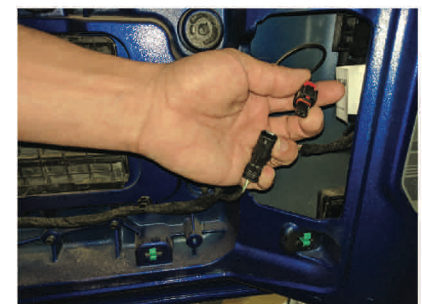

— LIGHT UP THE DARKNESS —



Step 25. You need to remove the 3 clips on the passenger side that are under a flip cover. Grab a Torx T40 driver and remove those bolts. This allows the plastic to be removed.

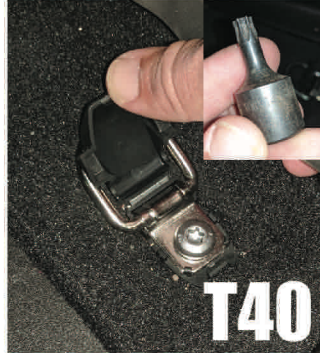

Step 26. Now you need to remove a T25 screw near the subwoofer. Then pry this strap opening and tie it up out of the way.



Step 27. Remove the taillight by loosening the white screw/hex bolt completely. (If you haven't in Step 3) There is a tensioner spring. Then pull away plastic liner starting in the front. Disconnect the subwoofer if equipped.

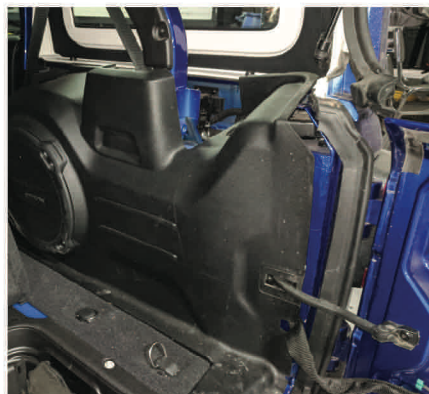



2018+ JEEP JL SEQUENTIAL 7" X 8" 30W LED TAILLIGHTS

QTE1026



VER: 20-2

Step 28. Cut the woven loom on either side of the hinge to pass the wires through. Use a rigid wire or other tool to assist in threading the Brake Signal Wire Adapter through.

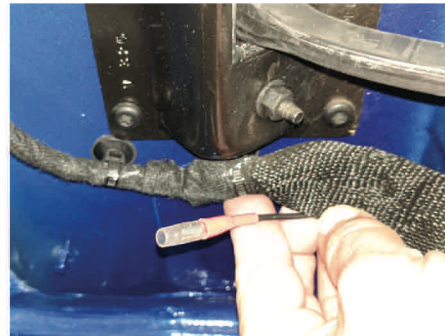
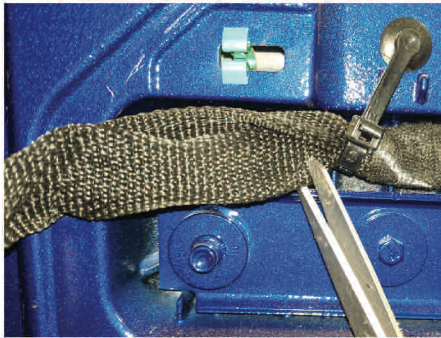

Step 29. Route the wires along existing loomed wire and affix with zip ties or tape. Pierce the grommet and feed the wire through into the tail light cavity



— LIGHT UP THE DARKNESS —



Step 30. Then route the driver side wire along the weather stripping at the bottom



Step 31. Remove the plastics on the Driver Side. They are much easier to remove on this side, also it is not required to remove the bed hook rail.





2018+ JEEP JL SEQUENTIAL 7" X 8" 30W LED TAILLIGHTS

QTE1026



VER: 20-2

Step 32. Reattach everything in reverse order. Be sure everything snaps back into place.



Lighthacker Module

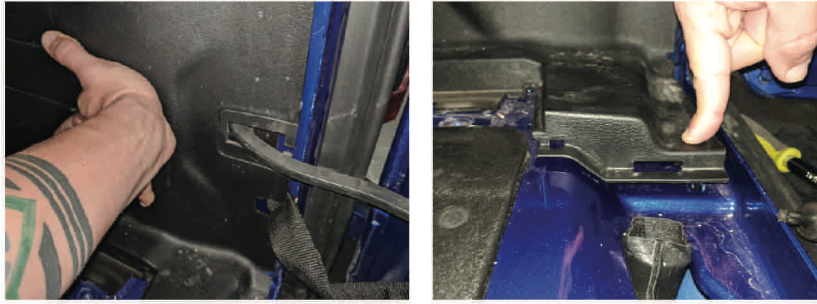

Step 33. Disconnect the red and yellow wires that are pre-connected to the tail lights. (Photo 19, @A&B)

Step 34. Now we will be connecting the Lighthacker Module (Photo 18). Connect the Lighthacker Module black wire to the long Brake Signal Wire Adapter black/red wire that you ran under the Gladiator near the tail gate. (Photo 20, @C)

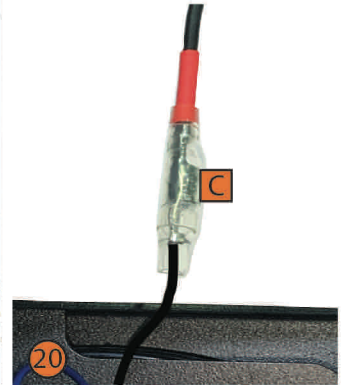
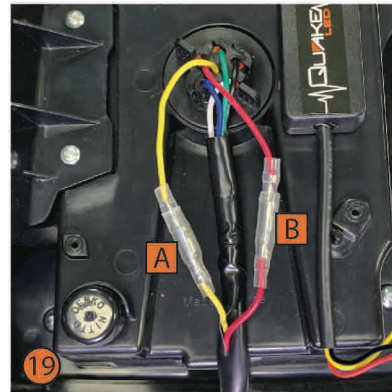

Step 35. Connect the Lighthacker Module's red wire to the red wire that is exiting the central wire plug we opened in step 12. (Photo 21, @D)

Step 36. Connect the long black Turn Signal wires that you installed during steps 8 thru 16 to the taillights short yellow wire near the central wire plug. (Photo 22, @G)

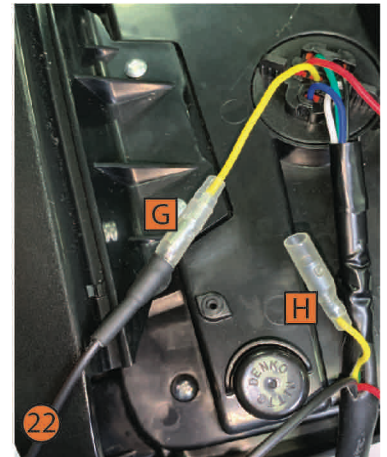

NOTE: There will be one yellow wire with a female connector that is not used in Lighthacker mode. (Photo 22, @H)

Step 37. If you have a STOCK HALOGEN HEADLIGHT trim JL keep on reading. If you have a STOCK LED HEDLIGHT trim JL, you can skip to Step 40.

Grab one Splitter Module and Quick Splice (Photo 23 and 24)



Connect the Lighthacker Module's yellow wire to the Splitter Module's black Wire. (Photo 25, @E)

Step 38. Connect the other Splitter Module's black wire to the tail light's main connector red wire that is coming out of the black wire loom. (Photo 26, @F)

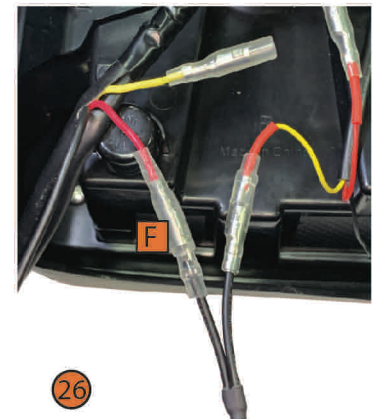
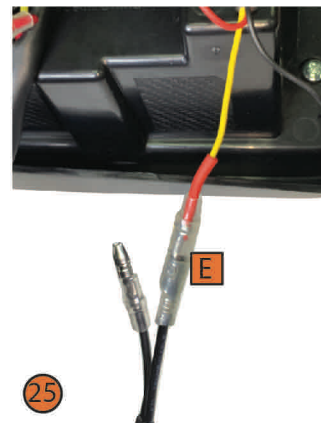

— LIGHT UP THE DARKNESS! —



2018+ JEEP JL SEQUENTIAL 7" X 8" 30W LED TAILLIGHTS

QTE1026



VER: 20-2

Step 39. Run the Splitter Module's long single black wire thru the plastic loom protecting the wires to the main tail light connector. You can thread the wire from a opening near the red and yellow connectors. (Photo 27) Quick Crimp this black wire to the tail light connector other black wire directly below the yellow wire. You can cut back the black plastic loom if there is not enough room. (Photo 28)

Step 40. This step is for STOCK LED HEADLIGHT customers only! Halogen customer can skip to Step 42. Connect the Lighthacker Module's yellow wire to the red wire that is coming out of the main connectors black wire loom. (Photo 30)

Step 41. FULLY COVER all the metal bullet connectors with it's clear plastic cover or it may cause a short circuit!!! The shorter cover will slip inside the larger cover. (Photo 31)

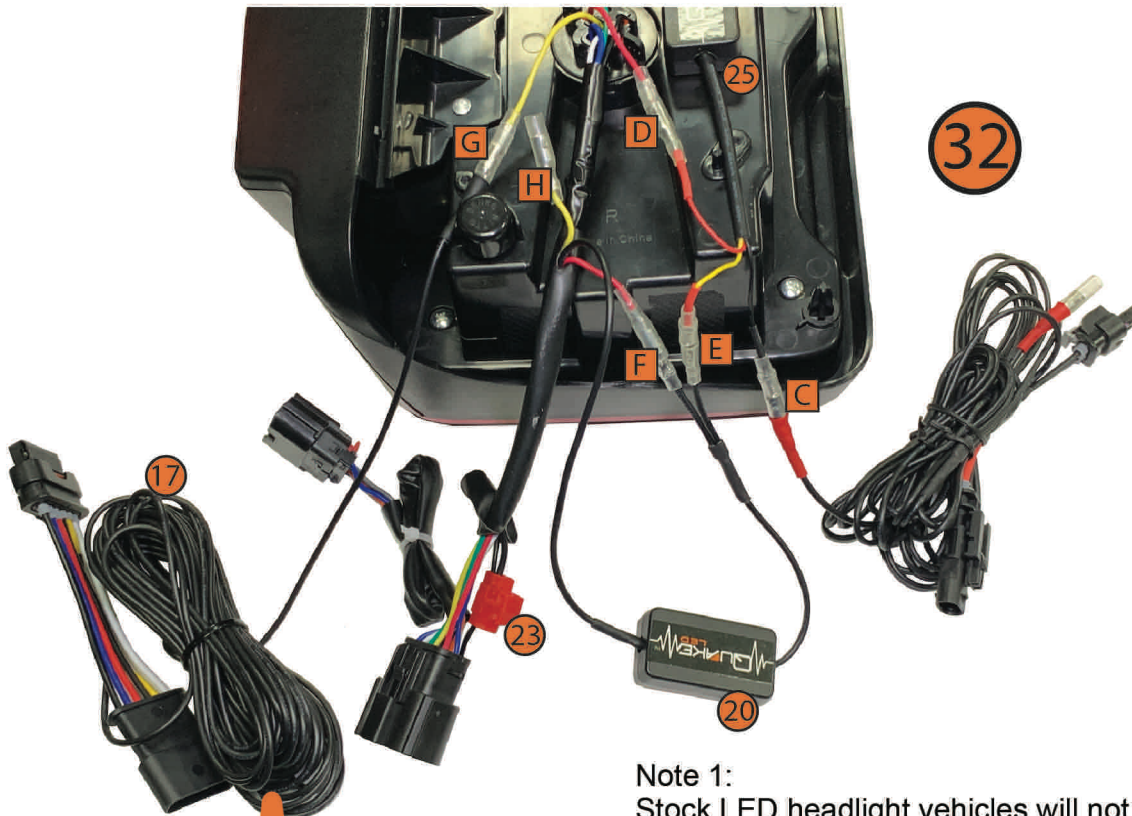
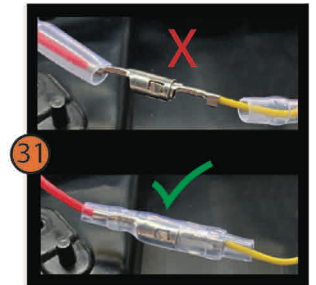
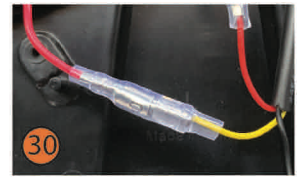
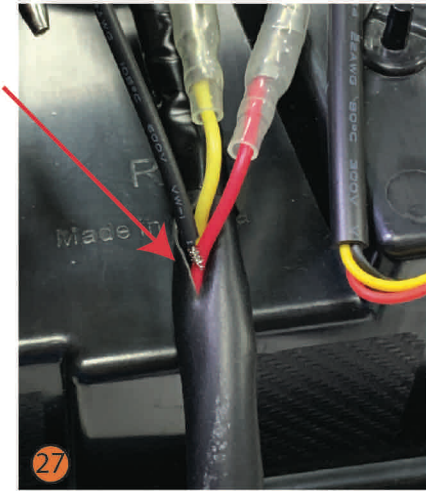

LIGHT HACKER CONNECTIONS

After you have completed all LightHACKER steps your taillight should be connected like this. (Photo 32)

Note 1:
Stock LED headlight vehicles will not need #20 installed. See Photo 30 for reference.



2018+ JEEP JL SEQUENTIAL 7" X 8" 30W LED TAILLIGHTS

QTE1026



VER: 20-2



Step 42. Plug in the tail lights connector to the stock tail light wire harness and check that all functions work.

Step 43. If all functions work. Reinstall the plastic mounting bracket that you removed in Step 7. All the wires should exit through the center bottom channel that is created once you reinstall the bracket.

Step 44. Halogen JL Vehicles ONLY: Secure the Splitter Module's to the top of the tail light mounting cone by removing the 3M adhesive film on the backside. Press the box to the plastic cover for 1 min in a normal indoor temperature. (not in cold snowy outdoor weather, smart guy!)

Now that you have the LIGHTHACKER installed. Reverse steps 1 thru 3 to re-install your new tail light and proceed to the other side. Do the same removal procedures and LIGHTHACKER installation.

Enjoy your new Quake LED JL Sequential Turn Signal LED Tail Lights!

LIGHT HACKER FUNCTION



LIGHT HACKER CONNECTOR

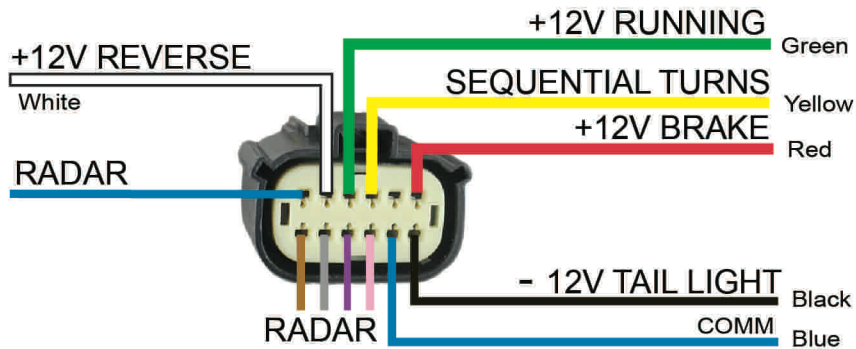

— LIGHT UP THE DARKNESS —